



The PMI Advanced  
**Capillary Pressure &  
Resistive Tester**  
CPRT-10K-A

Not just products...solutions!

# DESCRIPTION

A rock sample is held in the sample chamber and compressive stress is applied. While the sample is under compressive stress, the desired properties are measured. The PMI Automated Capillary Pressure and Resistive Tester is used to determine the properties of cut samples at certain confining pressure while measuring resistance. The PMI Automated Liquid Permeability System has been specially designed for testing core samples. Core samples are held in a Hassler type core holder which compresses the sample to the desired pressure. The test is run at ambient temperature. Non aqueous fluid such as oil, kerosene and aqueous fluid such as brine or equivalent can be used. The instrument measures the rate of a known amount of liquid to compute permeability. The equipment is fully automated. Execution of the test, data acquisition, data storage, & data management are all carried out by PMI Software. Operator involvement is minimal, and the

# PRINCIPLE

The PMI Automated Capillary Pressure and Resistive Tester is used to measure permeability of samples such as oil well cores, tight gas sandstones, and other low permeability rocks. Liquids such as brine, oil, and other fluids are used. The machine measures drop in pressure and flow rate through the sample during the test. PMI software uses Darcy's Law to compute permeability.

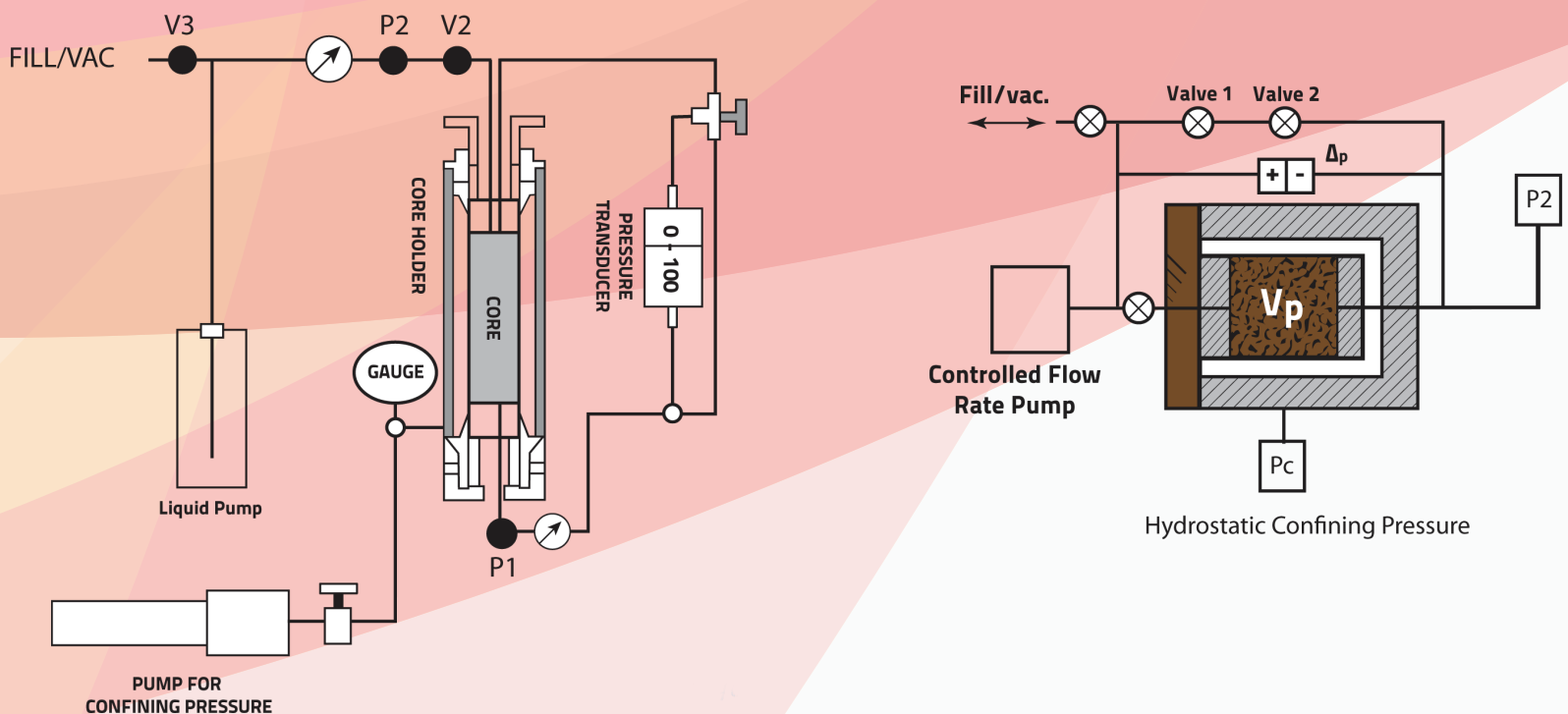

Figure 1

Outline of permeability testing setup

# APPLICATION

Industries worldwide utilize PMI Permeameters like the PMI Automated Liquid Permeability System for R&D and quality control. Applicable industries include: Oil Exploration Industries, Geotechnical Department, Geophysics, Automotive, and Battery Development.

# FEATURES

- Computer Processing and Data Storage
- Non-destructive testing
- Real-time graphical test display depicts testing status and results throughout operation
- All wetted parts made of 316 Stainless Steel for longevity in brine, water, refined oil, or dead oil
- User-friendly, Windows-based software handles all control, measurement, data collection, and report generation; complete manual control also possible
- PC system for data acquisition consists of core i5 Intel processor, 2GB ram, 300GB HDD, 17" monitor, latest operating system and MS office

# ACCESSORIES

- Core Holder - Hassler type Stainless construction
- Pressure Regulators - 0-100psi
- Pressure Transducer - 0-100 psi with 0.25% accuracy
- Calibration / reference material
- Duplicate copies of software, wiring /electrical / technical diagrams
- MSDS and test certificates for vessels, safety instructions and manual, including two hard copies and CD digital version of manual with troubleshooting and general maintenance information

# SAFETY FEATURES

- Limit Switches
- Software over-pressurization lockout for pump
- Rupture Disks
- Software monitors pressure drop, temperature, and confining pressure

# TESTING CAPABILITIES

Liquid Permeability (md) is based on the steady state Darcy method.

# SPECIFICATION

- Permeability Range: up to 5 Darcy
- Confining Pressure: up to 10000 psi (or more)
- Liquid Flow Range: 0.01-10cc/min or wider
- Flow (pore) Pressure Range: up to 750psi
- Capillary Pressure: up to 1500 psi or more
- Standard Core Plug Diameter: 1.5"
- Core Plug Length: Up to 5-7 CM long
- Power Requirements: 220-240 VAC 50 Hz 1 Phase
- Weight: 110 Kg

# SPARE PARTS

- 4-1.5" replacement sleeves
- 5-Seal kits for Pressure pumps
- 2 replacement automated valves
- 5 Ceramic disks
- 5 Semi permeable discs
- 5 Oil wet discs

# SALES & SERVICES

Our sales team is dedicated to helping our customers find which machine is right for their situation. We also offer custom machines for customers with unique needs. To find out what we can do for you, contact us.

We are committed to customer support including specific service products, short response times & customer specific solutions. To quickly & flexibly meet our customer's requirement, we offer a comprehensive range of services.



Customize your machine  
today!

**Disclaimer** : Other specifications of this product are also available. Specifications subject to change without notice. Design subject to change without notice.

The most advanced, accurate, easy to use  
and reproducible porometers in the world.

*Celebrating*



*of solutions*



20 Dutch Mill Rd, Ithaca, NY 14850, USA  
Toll Free (US & Canada): 1-800-TALK-PMI (1-800-825-5764)  
Phone: 607-257-5544 Fax: 607-257-5639

Email: [info@pmiapp.com](mailto:info@pmiapp.com)

[www.pmiapp.com](http://www.pmiapp.com)

